



INSTALL TIME: 1 hour



1

GET ORGANIZED

you will need:

- Suzuki Grand Vitara
- 4 mm Hex key
- 10 mm flat wrench and socket wrench
- Drill machine
- 9 mm drill bit
- Tube of silicone
- Clinch nut tool
- Utility knife
- Rubber mallet
- Panel tool or flat screw driver
- Insulation tape

...CONT'D

IMPORTANT WARNING!

IT IS CRITICAL THAT ALL FRONT RUNNER RACKS AND ACCESSORIES BE PROPERLY AND SECURELY ATTACHED TO YOUR VEHICLE. IMPROPER ATTACHMENT COULD RESULT IN AN AUTOMOBILE ACCIDENT, AND COULD CAUSE SERIOUS BODILY INJURY OR DEATH TO YOU OR TO OTHERS. YOU ARE RESPONSIBLE FOR SECURING THE RACKS AND ACCESSORIES TO YOUR CAR, CHECKING THE ATTACHMENTS PRIOR TO USE, AND PERIODICALLY INSPECTING THE PRODUCTS FOR ADJUSTMENT, WEAR, AND DAMAGE. THEREFORE, YOU MUST READ AND UNDERSTAND ALL OF THE INSTRUCTIONS AND CAUTIONS SUPPLIED WITH YOUR FRONT RUNNER PRODUCT PRIOR TO INSTALLATION OR USE. IF YOU DO NOT UNDERSTAND ALL OF THE INSTRUCTIONS AND CAUTIONS, OR IF YOU HAVE NO MECHANICAL EXPERIENCE AND ARE NOT THOROUGHLY FAMILIAR WITH THE INSTALLATION PROCEDURES, YOU SHOULD HAVE THE PRODUCT INSTALLED BY A PROFESSIONAL INSTALLER SUCH AS A QUALIFIED GARAGE OR AUTO BODY SHOP.

1 GET ORGANISED

...CONT'D

Here is what you are looking at:

ITEM	QUANTITY	DESCRIPTION
1	2	ROOF TRACK- 1 LEFT, 1 RIGHT
2	2	TRACK SEAL
3	10	ALUMINIUM SPACER
4	10	M6 X 30 COUNTERSUNK SCREW
5	4	M6 X 16 COUNTERSUNK SCREW
6	4	M6 CLINCH NUT

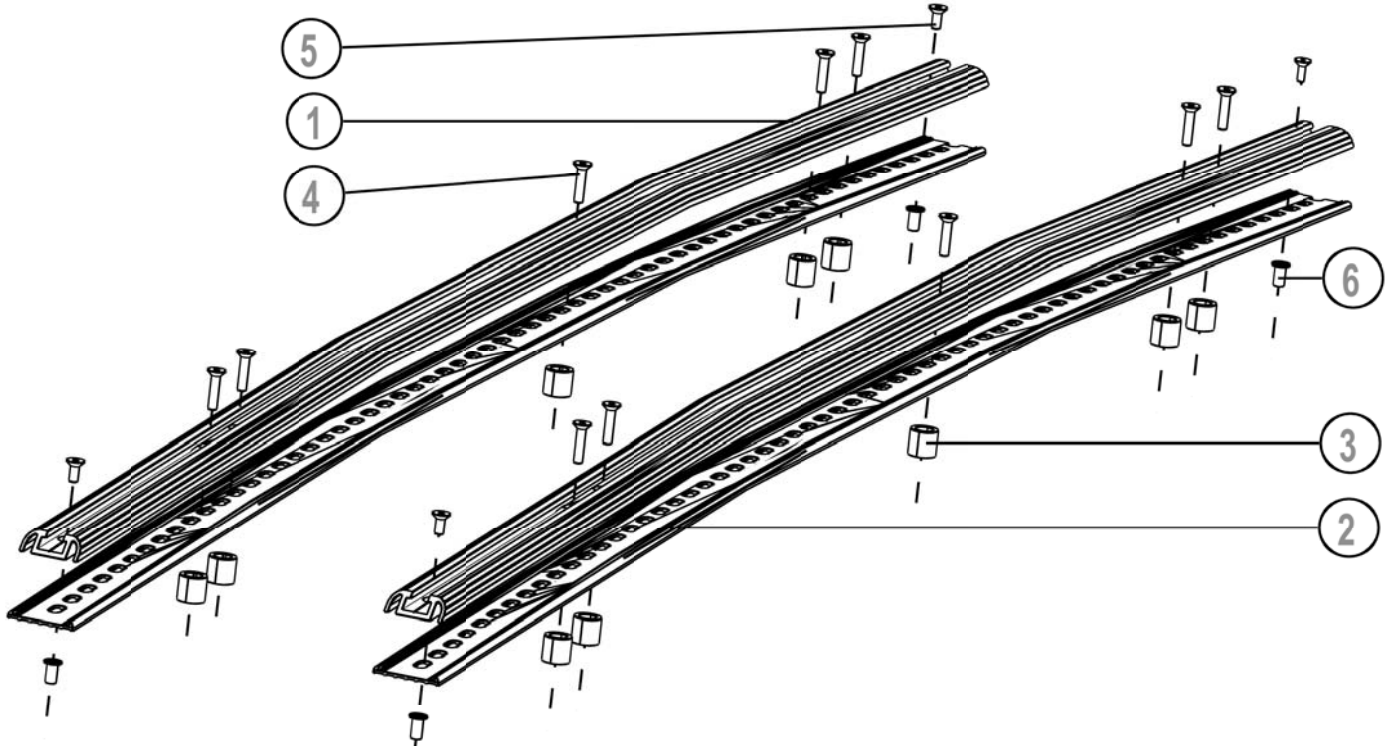

A)

Familiarize yourself with the parts and then step away from the work area and read through these instructions from beginning to end. Grab a cup of coffee and take a moment. A little prep now may save you a lot of time later.

2 REMOVE ORIGINAL TRACK

A)

Looking at the original tracks, you will see five plastic clips on either side. Using a panel tool or flat screw driver, unclip the clips.

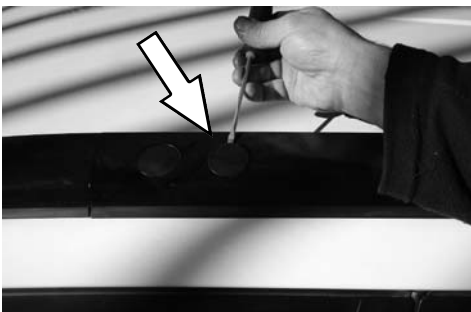

B)

Using a 10 mm wrench, loosen the ten M6 bolts.

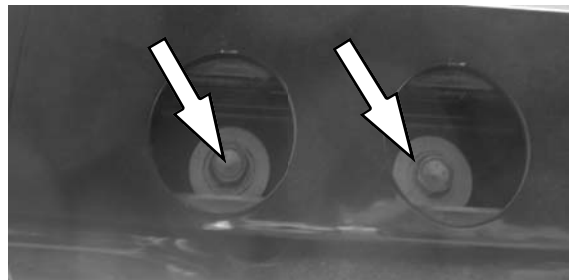

2 REMOVE ORIGINAL TRACK Cont...

C)

Using a panel tool or flat screw driver, unclip the original track in the front and rear of the vehicle and remove the tracks

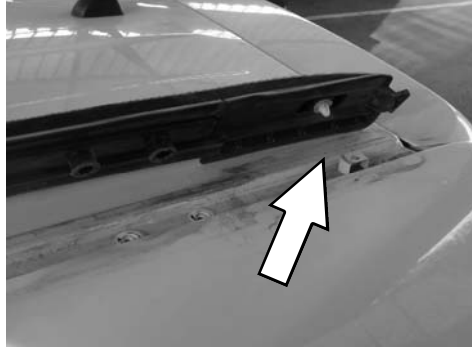

3 INSTALLATION OF TRACK

A)

Looking at the roof, you will see four original brackets at the front and rear of the vehicle. Using a drill machine and a 9 mm drill bit, drill each hole to 9 mm.

NOTE: On the drill bit measure 10 mm from the tip and wrap some insulation tape around the drill bit. This will stop you from drilling too deep and damaging the roof.

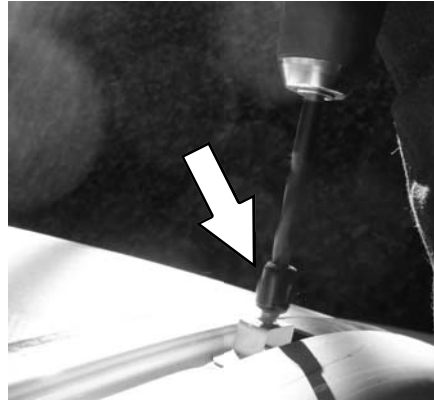

B)

Using a clinch nut tool, fit a M6 clinch nut to each hole drilled in Step 3 A.

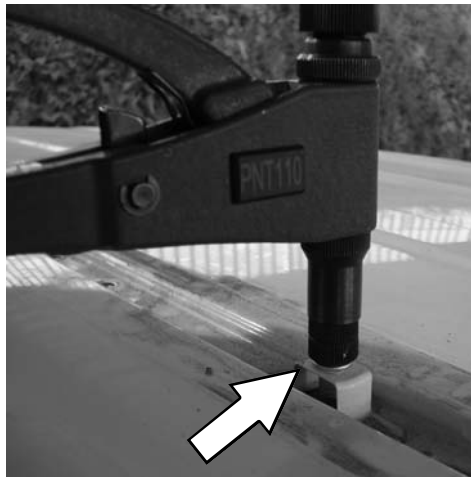

C)

Using a rubber mallet, gently knock each clinch nut/bracket down so they are level with the roof channel as shown by the line.

NOTE: The clinch nut/bracket only needs to be knocked down 1 to 2 mm only.

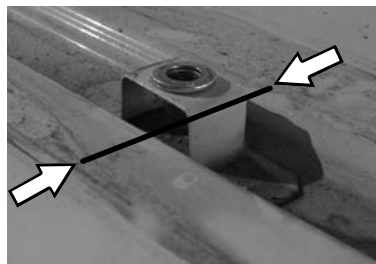

3 INSTALLATION OF TRACK Cont...

D)

Place some silicone into each of the original Threaded holes. Place an aluminium spacer (Item 3) on top of the silicone lining it up with the threaded hole.

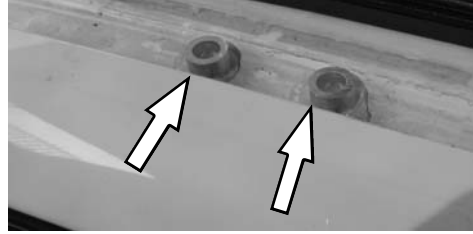

E)

The aluminium Tracks ship with the rubber seal loosely fitted in place. There are two quick steps to prep the seal and tracks. First, remove the paper to expose the glue. Then carefully centre the holes in the seal with the holes in the track and press the seal into place. Using your utility knife trim the rubber at the end of each track so it doesn't overhang.

F)

Place the Tracks on the roof with the curved side to the front of the vehicle lining up the holes in the track with the threaded holes in the roof. Insert a M6 x 16 Countersunk Bolt (Item 5) in the hole at the back of the vehicle.

On the next five holes insert M6 x 30 Countersunk Bolts (Item 4) for the last hole in the front of the vehicle, insert a M6 x 16 Countersunk Bolt. Tighten all bolts using a 4 mm allen key.



Congratulations, you have completed the Track installation.

4 INSTALL YOUR RACK OR LOAD BARS.

See the specific install guides.

Modifying your vehicle involves some risks and may void certain aspects of your vehicle's warranty.